

Quick Installation Guide
Guía de instalación rápida
Guide d'installation rapide

Tools Needed

Herramientas necesarias
Outils nécessaires

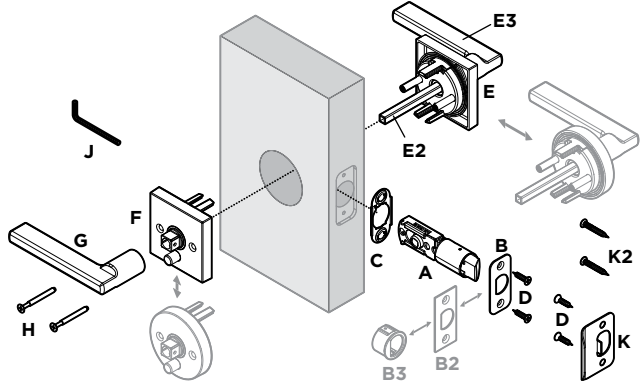
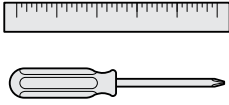

1

Check Dimensions

Revise las medidas
Vérifier les dimensions

See drilling instructions on page 4 if needed.

Ver las instrucciones para taladrar en la página 4 si es necesario.

Voir les instructions de perçage sur la page 4 si nécessaire.

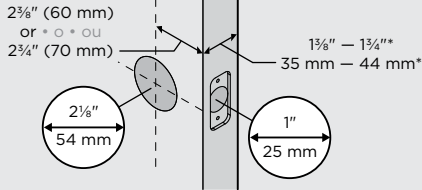

*Thick door service kits for 2 3/4" (57 mm) thick doors available through customer service.

*El servicio al cliente tiene juegos de reparación para puertas de 57 mm (2 3/4") de espesor.

*On peut se procurer des trousse de service pour portes d'une épaisseur de 57 mm (2 3/4") au près du service à la clientèle.

2

Adjust Latch "A" (if needed)

Ajuste el pestillo "A" (si es necesario)
Ajuster le verrou "A" (si nécessaire)

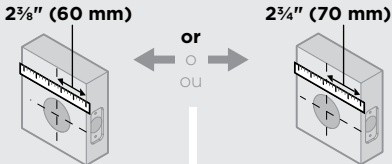

Proceed to Step 3.

Vaya al paso 3.

Passez à l'étape 3.

3

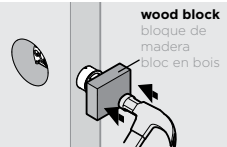
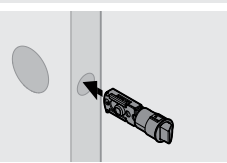
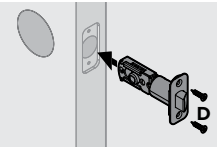
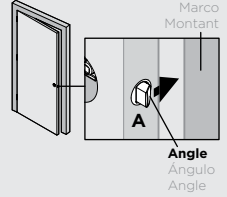
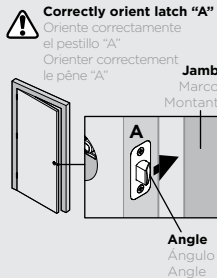
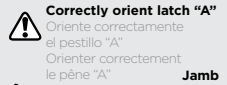
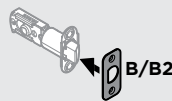
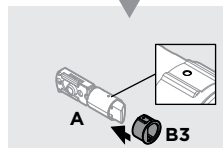
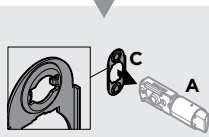
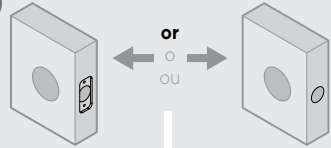

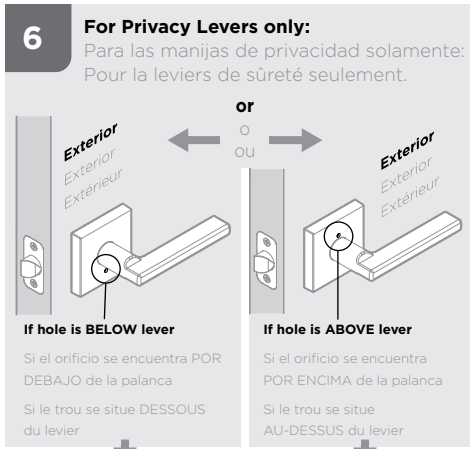
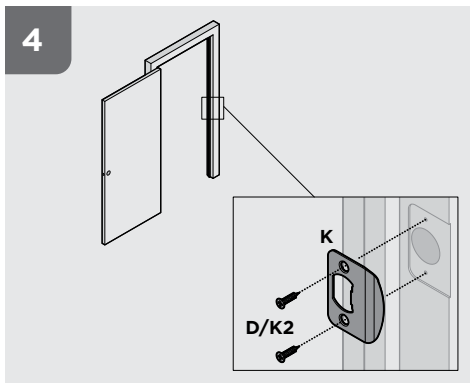

Proceed to Step 7.
 Vaya al paso 7.
 Passez à l'étape 7.

Proceed to page 3 and follow steps i-ix to reorient lever.
 Vaya a la página 3 y siga los pasos i-ix para reorientar la palanca.
 Passez à la page 3 et suivez les étapes i-ix pour réorienter le levier.

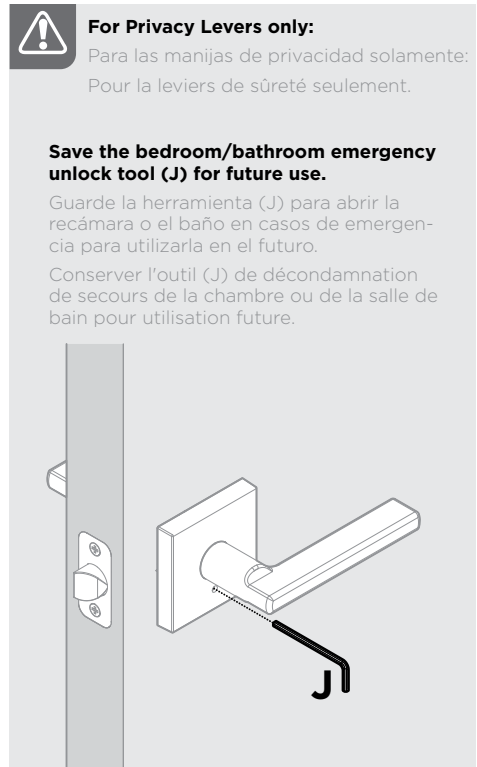
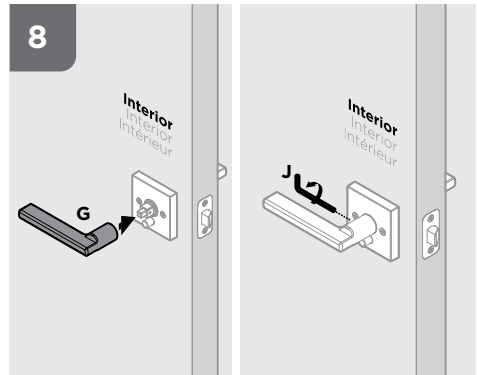
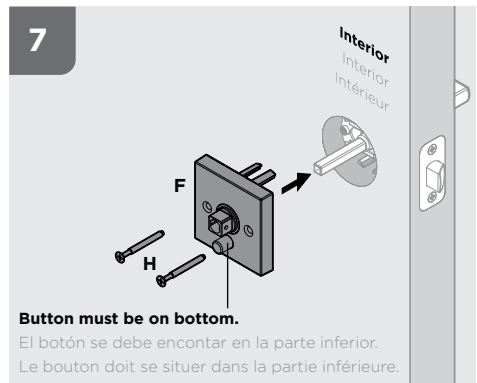

i**Only perform steps i-ix if lever reorientation is required.**

Solo lleve a cabo los pasos i-ix si se requiere la reorientación de la palanca.
 Exécuter les étapes i-ix uniquement si la réorientation du levier est requise.

Exterior
 Exterior
 Extérieur

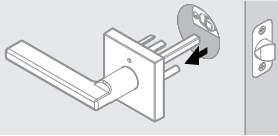
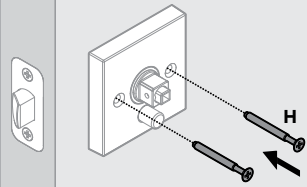
**vi****ii****Caution: "E2" is spring-loaded.**

Precaución: "E2" se encuentra accionado por resorte.
 Attention: "E2" est à ressort.

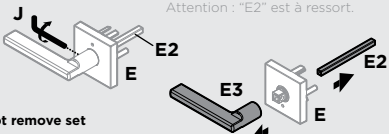

Do not remove set screw from lever.

No retire el tornillo de fijación de la manija.

Ne pas enlever la vis pression à partir de levier.

vii**Install interior lever before installing exterior lever.**

Instale la manija interior antes de instalar la manija exterior.

Installer le levier de l'intérieur avant d'installer le levier extérieur.

Interior
 Interior
 Intérieur

Lever handle faces away from latch.

La manija va orientada hacia fuera del pestillo.

Le levier est orienté dans le sens opposé du pêne.

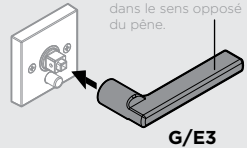
**iii**

Exterior
 Exterior
 Extérieur

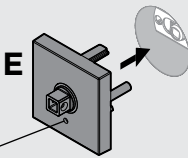

Hole must be on bottom.

El orificio se debe encontrar en la parte inferior.

Le trou doit se situer dans la partie inférieure.

viii

Interior
 Interior
 Intérieur

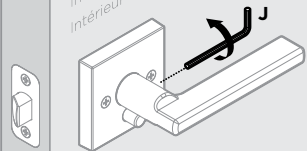
**iv**

Interior
 Interior
 Intérieur

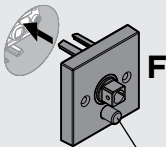

Button must be on bottom.

El botón se debe encontrar en la parte inferior.

Le bouton doit se situer dans la partie inférieure.

ix

Exterior
 Exterior
 Extérieur

G/E3

Exterior
 Exterior
 Extérieur

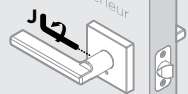
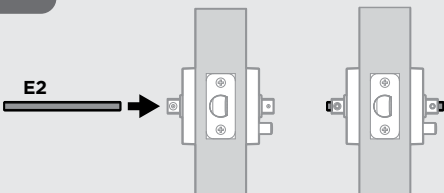
**v****For Privacy Levers only:**

Para las manijas de privacidad solamente:
 Pour les leviers de sûreté seulement.

Save the bedroom/bathroom emergency unlock tool (J) for future use.

Guarde la herramienta (J) para abrir la recámara o el baño en casos de emergencia para utilizarla en el futuro.

Conserver l'outil (J) de décondamnation de secours de la chambre ou de la salle de bain pour utilisation future.

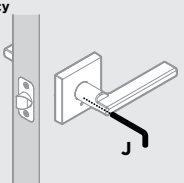

Edge • Borde • Champ

Face • Frente • Face

Template • Plantilla • Gabarit

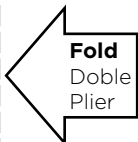
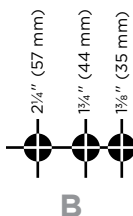

Centerline
Línea central
Ligne médiane

2 3/8" (60 mm)

2 3/4" (70 mm)

Backset

Distancia al centro

Écartement

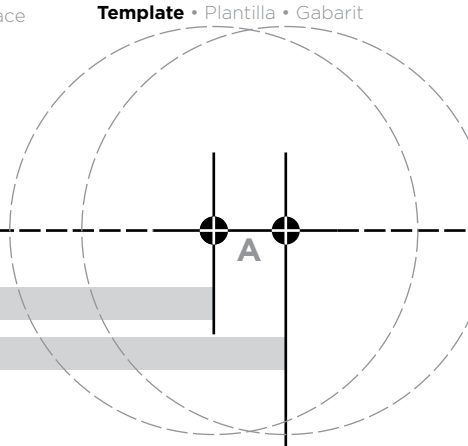

1

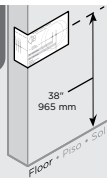

Place the template on the EXTERIOR side of door. Fold template along fold line and place fold line along the edge of door with the centerline approximately 38" (965mm) from floor.

Coloque la plantilla en el lado EXTERIOR de la puerta. Doble la plantilla a lo largo del doblez y coloque el doblez a lo largo del borde de la puerta con la línea central a unas 38" (965mm) del suelo.

Placer le gabarit sur l'extérieur de la porte. Plier le gabarit le long de la ligne de pliage et placer la ligne de pliage le long du bord de la porte, avec l'axe à environ 38" (965mm) du sol.

6

Mark holes

Marque los orificios

Marquer les trous

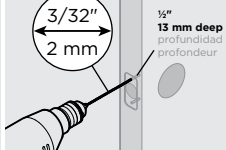

2

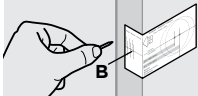
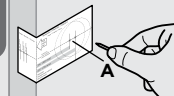

Mark hole A. Select desired backset before marking hole.

Marque el orificio A. Seleccione la distancia al centro deseada antes de marcar el orificio.

Marquez le trou A. Sélectionnez écartement désirée avant de marquer le trou.

Mark hole B. Select door thickness before marking hole.

Marque el orificio B. Seleccione grosor de la puerta antes de marcar el orificio.

Marquez le trou B. Sélectionnez épaisseur de la porte avant de marquer le trou.

7

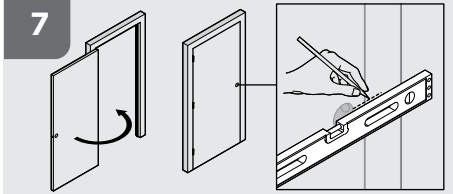

3

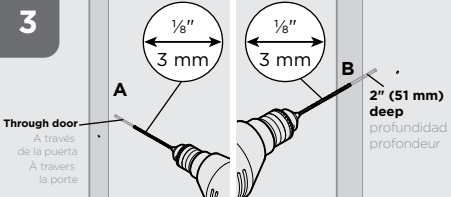

Through door
A través de la puerta
À travers la porte

8

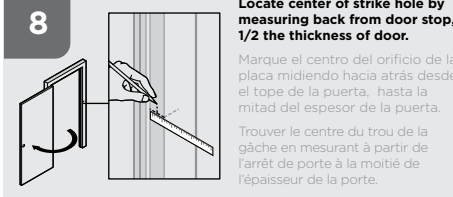

Locate center of strike hole by measuring back from door stop, 1/2 the thickness of door.

Marque el centro del orificio de la placa midiendo hacia atrás desde el tope de la puerta, hasta la mitad del espesor de la puerta.

Trouver le centre du trou de la gâche en mesurant à partir de l'arrêt de porte à la moitié de l'épaisseur de la porte.

4

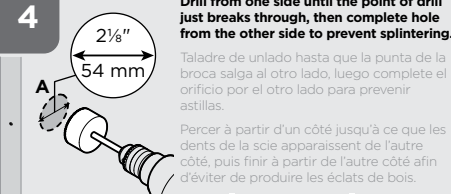

Drill from one side until the point of drill just breaks through, then complete hole from the other side to prevent splintering.

Taladre de un lado hasta que la punta de la broca salga al otro lado, luego complete el orificio por el otro lado para prevenir astillas.

Perçer à partir d'un côté jusqu'à ce que les dents de la scie apparaissent de l'autre côté, puis finir à partir de l'autre côté afin d'éviter de produire les éclats de bois.

9

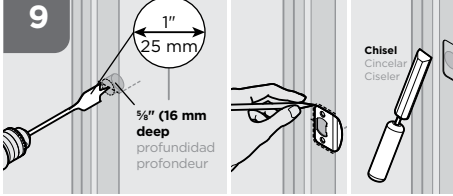

Chisel
Cincelar
Ciseler

5

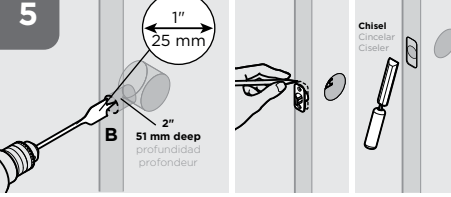

10

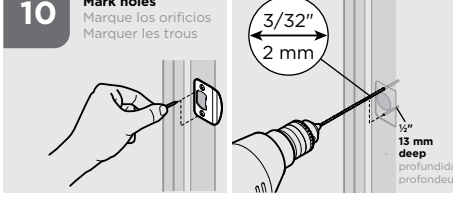

Mark holes

Marque los orificios

Marquer les trous

1/8" 13 mm deep
profundidad
profondeur